

TC-140, 141 TRANSFER CASE PARTS MANUAL

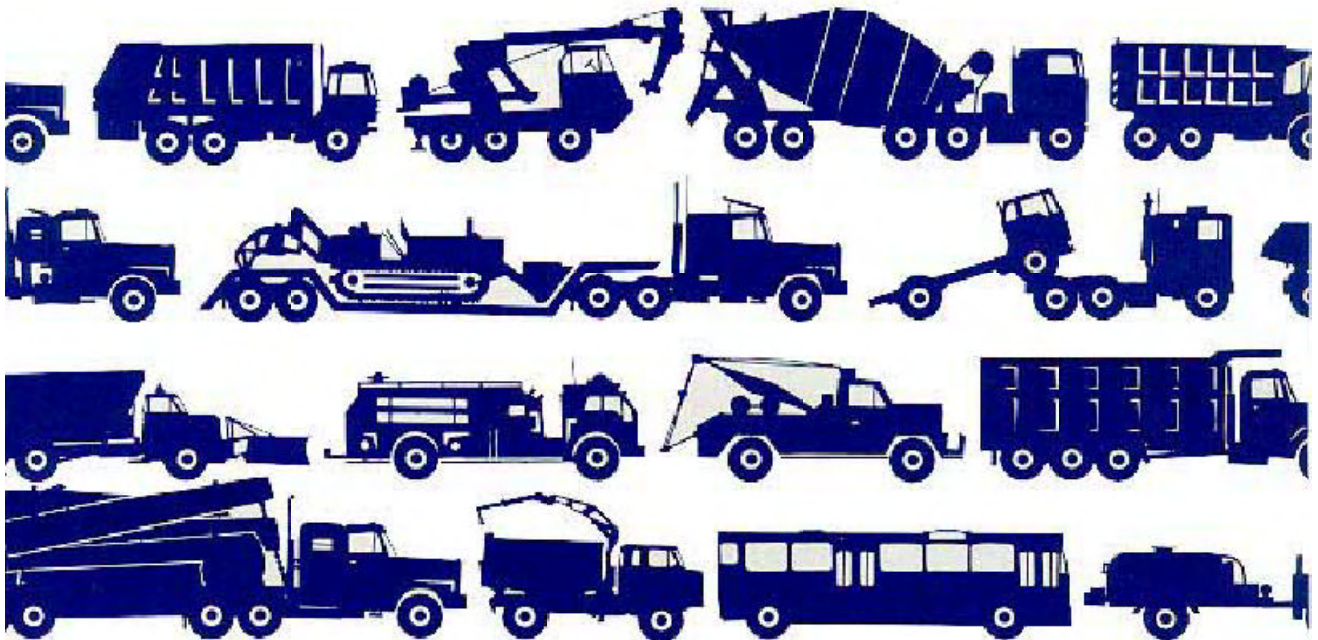

Telephone (925) 454-9500 Fax (925) 454-9501
151 Lawrence Drive, Livermore, CA 94551



X. PARTS MANUAL

PARTS MANUAL TC 140 TRANSFER CASE TWO SPEED, TC-141 SINGLE SPEED

This manual covers three styles of the TC 140 transfer case: Declutch, 26/74 differential, and 50/50 differential.

Table of Contents

TRANSFER CASE HOUSING	pm 3
SHAFTS	pm 5
SHIFT SHAFT	pm 7
DECLUTCH	pm 9
P.T.O.	pm 11
LOCKOUT	pm 13
26/74 LOWER SHAFT	pm 15
50/50 LOWER SHAFT	pm 17
LUBRICATION PLUMBING	pm 19
OVERHAUL KITS	pm 20

TO USE THIS BOOK:

1. Refer to the exploded view illustrating the needed part. Note the item number of the part.
2. Refer to the proper parts list and convert the item number to a part number.
3. When ordering parts, specify part number, part name and the quantity desired.

NOTE:

When ordering parts for a Fabco Transfer Case please use the Fabco nameplate to specify model number, serial number, part number, ratio and any other information which is called out on the nameplate. The Fabco nameplate will be located on the transfer case housing.

X. PARTS MANUAL

TRANSFER CASE HOUSING and related parts

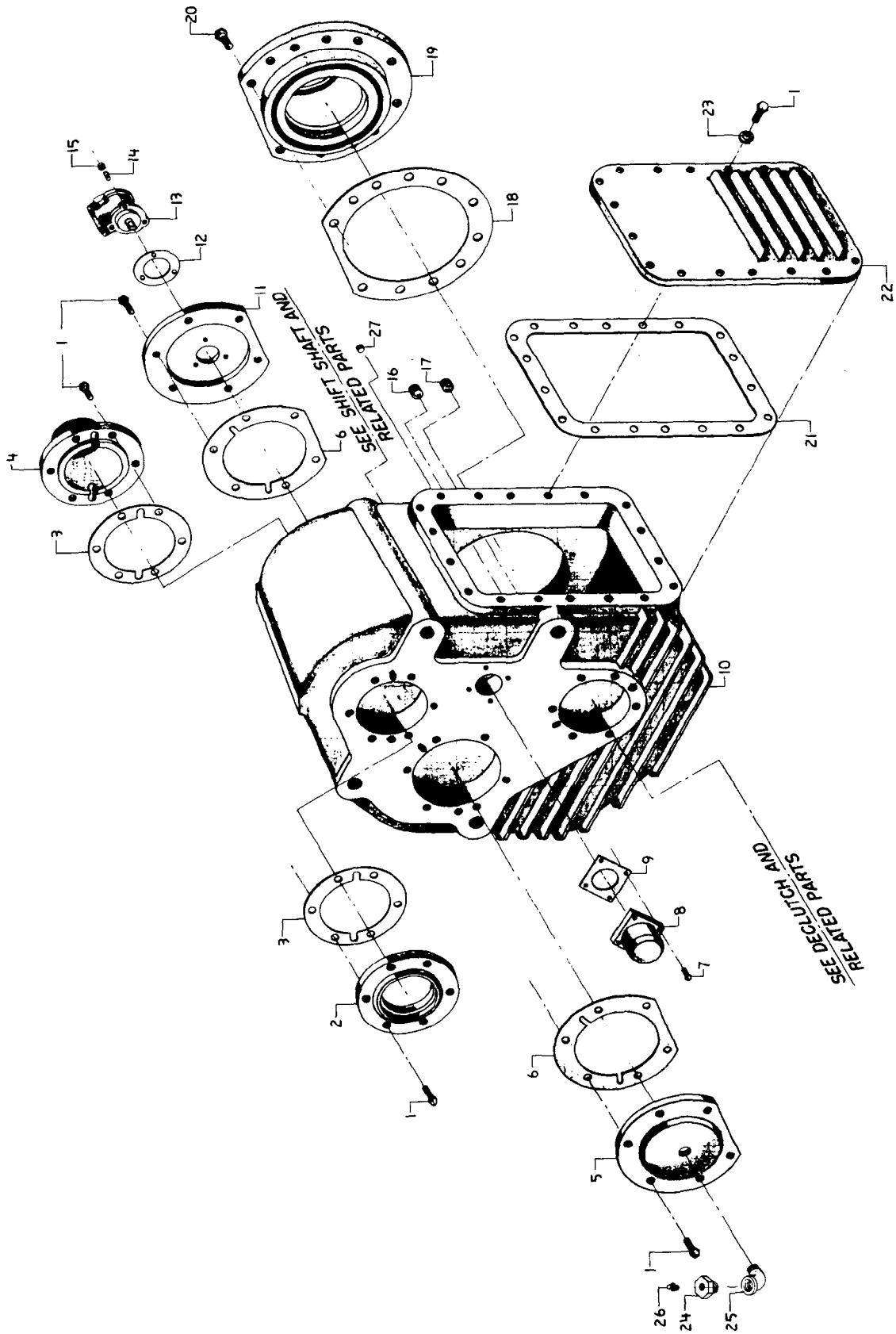

X. PARTS MANUAL

TRANSFER CASE HOUSING AND RELATED PARTS

ITEM	PART NO.	DESCRIPTION	BASIC
1	265 238	Bolt, 7/16-14 × 1¼ Grade 5	42
2	237 357	Carrier, Upper Shaft Front Seal	1
3	427 372	Gasket, Upper Shaft, Seal Carrier	2
4	235 368	Cap, Upper Shaft Rear (Exc. PTO & DPD)	1
5	235 543	Cap, Intermediate Shaft Front	1
6	427 428	Gasket, Intermediate Shaft Cap	2
7	265 386	Bolt, 1/4-20 × 3/4 Grade 5	4
8	235 388	Cap, Shift Shaft	1
9	427 399	Gasket, Shift Shaft	1
10	468 586	Housing, Transfer Case	1
11	235 386	Cap, Intermediate Shaft Rear	1
12	427 435	Gasket, Oil Pump	1
13	786 283	Pump, Oil	1
14	788 546 005	Stud, ¼-20 × ¼-28 × 1¼	3
15	688 692	Nut, Esna, ¼-28	3
16	758 268	Plug, 3/4 Pipe	1
17	758 274	Plug, 3/4 Magnetic Pipe	1
18	427 432	Gasket, Lower Shaft Speedometer and Seal Carrier	1
19	237 374	Carrier, Lower Shaft Speedometer and Seal	1
20	265 363	Bolt, ½-13 × 1½ Grade 5	11
21	427 434	Gasket, Cover Plate	1
22	793 275	Plate, Transfer Case Cover	1
23	927 684	Washer, Flat, 7/16	18
24	356 236	Bushing, Hex Reducer, ¾-1/8	1
25	359 267	Elbow, 90° Street, ¾ NPT	1
26	836 222	Breather, 1/8 NPT	1
27	758 255	Plug, Square HD, ¼ NPT	1

X. PARTS MANUAL

SHAFTS and related parts

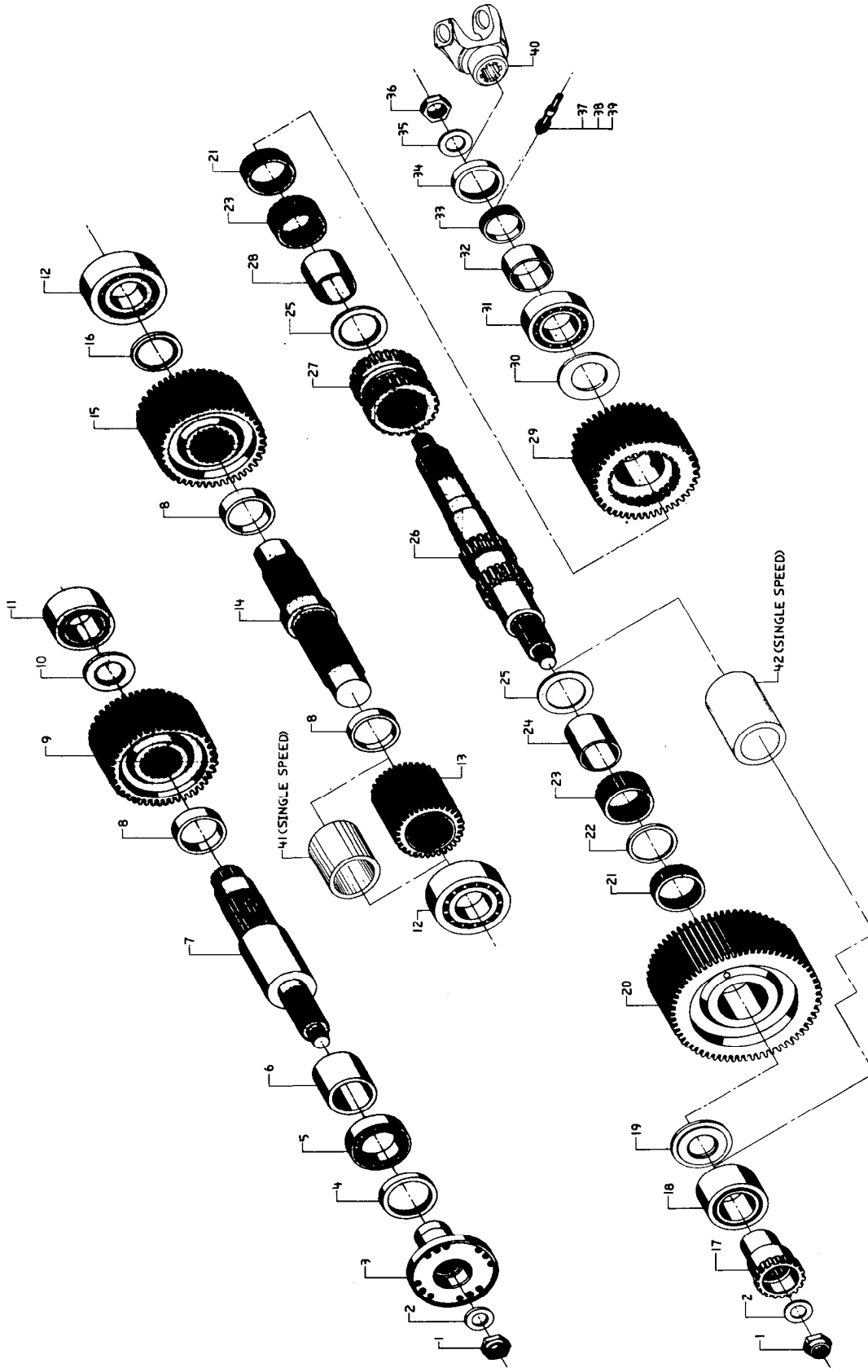

SHAFTS AND RELATED PARTS

ITEM	PART NO.	DESCRIPTION	QTY
1	688 639	Nut, Self Locking 1½-18	2
2	927 775 005	Washer, Input Flange Nut	2
3	352 398 352 427	Flange, Input, 1810 Flange, Input, 1710	1
4	732 328	Seal, Input Flange	1
5	232 372	Bearing, Upper Shaft Front	1
6	736 839	Tube, Upper Shaft Front Spacer	1
7	742 986	Shaft, Upper	1
8	736 887	Ring, Shaft Spacer	3
9	432 479	Gear, Upper Shaft Input (48 Tooth)	1
10	736 894	Ring, Upper Shaft Rear Spacer	1
11	232 373	Bearing, Upper Shaft Rear	1
12	232 375	Bearing, Intermediate Shaft	2
13	432 483	Gear, Intermediate Shaft Underdrive (31 Tooth)	1
14	742 893	Shaft, Intermediate	1
15	432 482	Gear, Intermediate Shaft Direct Drive (49 Tooth)	1
16	927 699	Ring, Intermediate Shaft Rear Spacer	1
17	432 489	Gear, Declutch	1
18	232 378	Bearing, Lower Shaft Front Ball	1
19	927 697	Washer, Lower Shaft Front Thrust	1
20	432 484	Gear, Lower Shaft Underdrive (66 Tooth)	1
21	765 284	Bearing, Lower Shaft Narrow Needle	2
22	736 835	Ring, Lower Shaft Needle Bearing Spacer	1
23	765 285	Bearing, Lower Shaft Wide Needle	2
24	233 434	Race, Lower Shaft Front Needle Bearing	1
25	927 694	Washer, Lower Shaft Inner Thrust	2
26	742 895	Shaft, Lower	1
27	432 485	Collar, Clutch	1
28	233 433	Race, Lower Shaft Rear Needle Bearing	1
29	432 488	Gear, Lower Shaft Direct Drive (48 Tooth)	1
30	927 696	Washer, Lower Shaft Rear Thrust	1
31	232 369	Bearing, Lower Shaft Rear	1
32	883 676	Spacer, Speedometer Drive Gear	1
33	432 432	Gear, Speedometer Drive	1
34	732 355	Seal, Lower Shaft Rear Output	1
35	927 775 006	Washer, Rear Output Yoke Nut	1
36	688 642	Nut, Self Locking 1¾-16	1
37	432 429	Gear, Speedometer Driven (13 Tooth)	1
38	882 299	Tube, Speedometer Driven Gear (Prior to 1980)	1
39	883 473	Sleeve, Speedometer Driven Gear	1
40	965 843 965 836	Yoke, End, Rear Output (1710) Yoke, End, Rear Output (1810)	1
TC-141 ONLY			
41	736 927	Spacer, Intermediate Shaft (Replaces Item 13)	1
42	736 928	Spacer, Lower Shaft (Replaces Items 19 thru 25, QTY 1 each)	1

SHIFT SHAFT and related parts

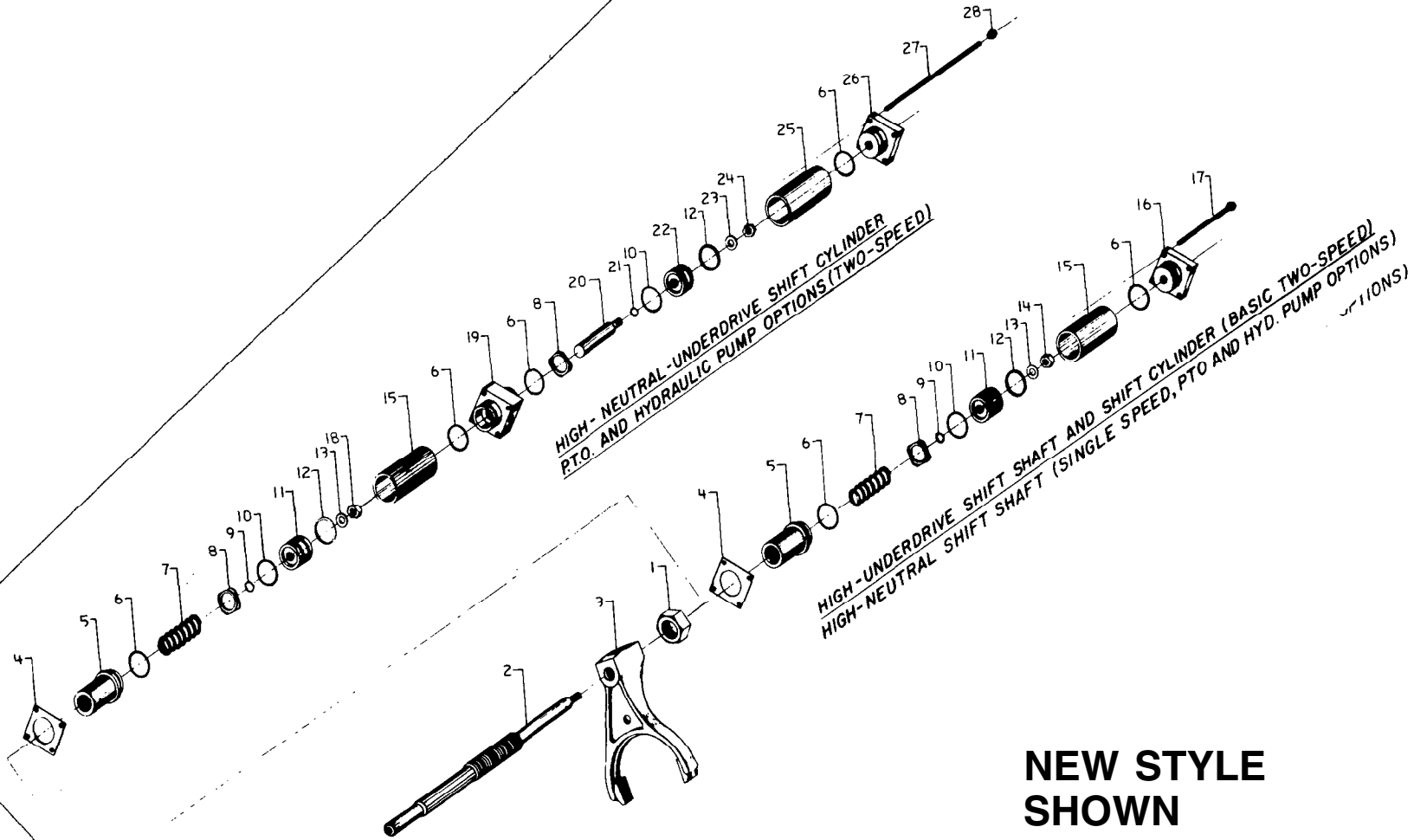

SHIFT SHAFT AND RELATED PARTS

ITEM	PART NO.	DESCRIPTION	BASIC P-SPEED	PTO &
			& SINGLE SPEED	DIRECT PUMP
			w/PTO & DPD	DRIVE
1	688 245	Nut, Jam	1	1
2	769 354	Shaft, Shift	1	1
3	367 278	Fork, Underdrive	1	1
4	427 399	Gasket, Shift Shaft	1	1
5	883 683	Tube, Shift Cylinder Adapter	1	1
6	675 224	O-Ring, 1¾ I.D.	2	4
7	777 486	Spring, Shift Shaft	1	1
8	736 747	Ring, Stop	1	2
9	675 014	O-Ring, Piston Seal	1	1
10	339 223	Wiper, Felt	1	2
11	753 245	Piston, Shift	1	1
12	675 326	O-Ring, 1⅝ I.D.	1	2
13	927 553	Washer, Piston Nut	1	1
14	688 725	Nut, Flexloc	1	—
15	883 887 005	Tube, Shift Cylinder (3.50" Long)	1	1
16	235 528	Cap, Shift Cylinder	1	—
17	265 772	Bolt, ¼-20 × 4½ Grade 5	4	—
18	688 726	Nut, Special	—	1
19	883 893	Adapter, Neutral Cylinder	—	1
20	769 389	Shaft, Neutral Shift	—	1
21	782 288	O-Ring, Piston Seal	—	1
22	753 232	Piston, Shift	—	1
23	927 643	Washer, Piston Nut	—	1
24	688 464	Nut, Flexlock	—	1
25	883 887 006	Tube, Shift Cylinder, (3.062" Long)	—	1
26	235 352	Cap, Shift Cylinder	—	1
27	788 546 002	Stud, ¼-20 × 9	—	4
28	688 395	Nut, ¼-20	—	4

DECLUTCH and related parts

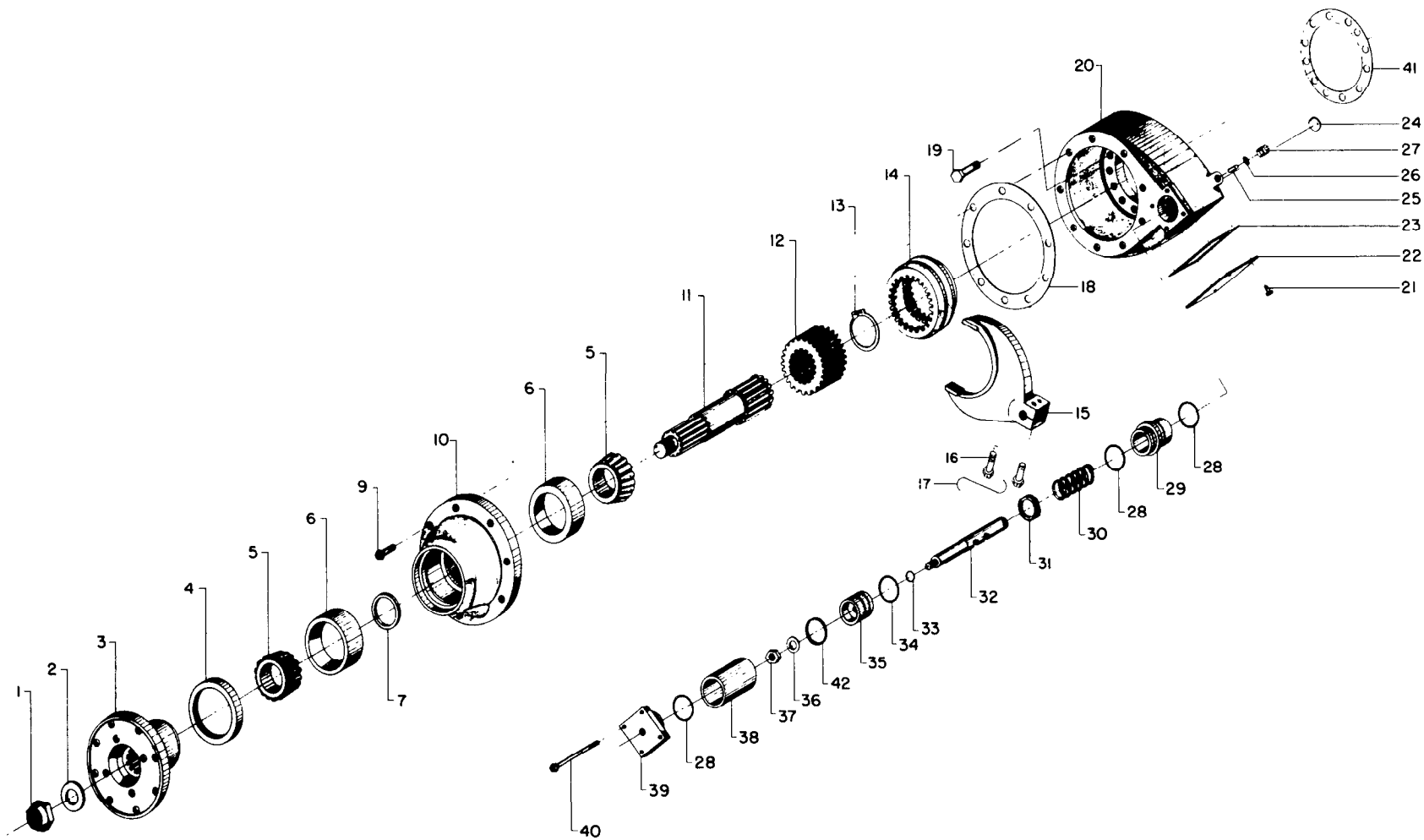

DECLUTCH AND RELATED PARTS

ITEM	PART NO.	DESCRIPTION	QTY				QTY	
1	688 633	Nut, Self Locking 1¼-18	1	29	883 482	Tube, Declutch Shift Cylinder Adapter	1	
2	927 775 002	Washer, Declutch Flange Nut	1	30	777 477	Spring, Declutch Shift Shaft	1	
3	352 428	Flange, Front Output (1710)	1	31	736 747	Ring, Stop	1	
	352 383	Flange, Front Output (1810)		1				
4	732 328	Seal, Front Output	1	32	742 799	Shaft, Declutch Shift	1	
5	233 377	Bearing, Declutch Cone	2	33	782 288	O-ring, Piston seal	1	
6	233 376	Cup, Declutch Bearing	2	34	339 223	Wiper, Felt	1	
7	736 767	Ring, Declutch Spacer (.323)	1	35	753 232	Piston, Shift	1	
	736 797	Ring, Declutch Spacer (.328)		(As Req'd)	36	927 643	Washer, Piston Nut	1
	736 896	Ring, Declutch Spacer (.313)		1	37	688 464	Nut, Flexloc	1
	736 897	Ring, Declutch Spacer (.318)		1	38	883 877 001	Tube, Shift Cylinder (2.75" Long)	1
9	265 238	Bolt, 7/16-14 × 1¼ Grade 5	8	39	235 352	Cap, Shift Cylinder	1	
10	237 359	Carrier, Declutch	1	40	265 769	Bolt, ¼-20 × 3¾ Grade 5	4	
11	742 797	Shaft, Declutch Output	1	41	427 449	Gasket, Declutch Housing	1	
12	432 427	Gear, Clutch	1	42	675 326	O-ring, 1 5/8 I.D.	1	
13	762 288	Ring, Snap, Declutch Output Shaft	1					
14	432 426	Collar, Clutch	1					
15	367 254	Fork, Declutch Shift	1					
16	265 768	Bolt, 7/16-14 × 2¼ Grade 5	2					
17	947 223	Wire, #18 Gauge (.048) × 5½ Lock	1					
18	427 375	Gasket, Declutch Carrier	1					
19	724 677	Cap Screw, Ferry Head, 7/16-14 × 2¼	6					
20	468 633	Housing, Declutch	1					
21	265 343	Bolt, ¼-20 × ½ Grade 5	1					
22	792 866	Plate, Declutch Cover	1					
23	427 376	Gasket, Declutch Cover Plate	1					
24	758 328	Plug, 1" Welch	1					
25	746 628	Plunger	1					
26	927 427	Washer, Copper	1					
27	798 245	Switch, Shift Indicating	1					
28	675 224	O-ring, 1¾ I.D.	1					

PTO, DIRECT PUMP DRIVE and related parts

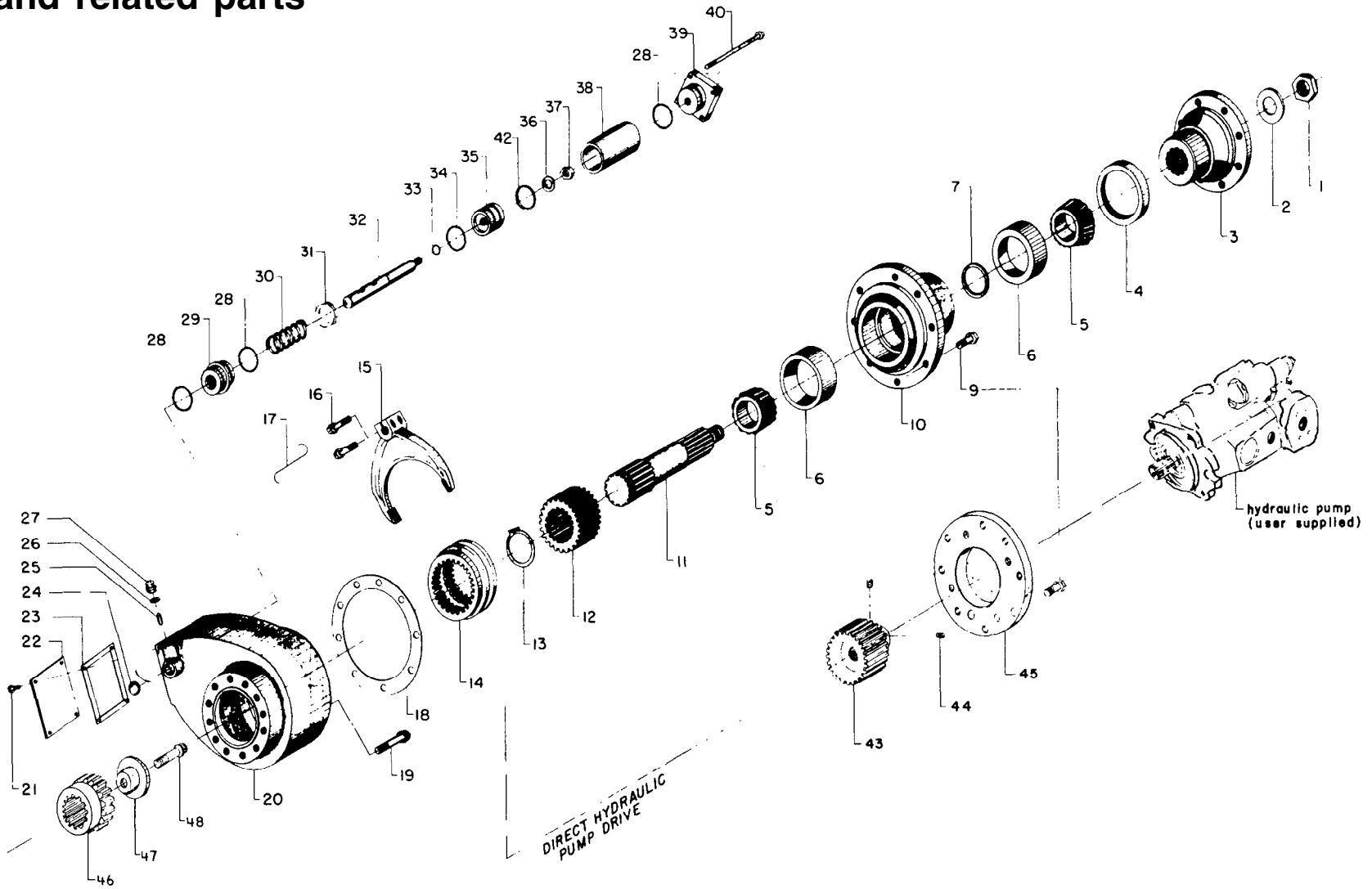

+P.T.O AND RELATED PARTS

ITEM	PART NO.	DESCRIPTION	QTY					
P.T.O. ONLY								
1	668 633	Nut, Self Locking 1¼-18	1	29	883 482	Tube, PTO Shift Cylinder Adapter		1
2	927 775 002	Washer, PTO Flange Nut	1	30	777 477	Spring, PTO Shift Shaft		1
3	352 344	Flange, PTO	1	31	736 747	Ring, Stop		1
4	732 328	Seal, PTO Flange	2	32	742 799	Shaft, PTO Shift		1
5	233 377	Cone, PTO Bearing	2	33	782 288	O-ring, Piston seal		1
6	233 376	Cup, PTO Bearing	1	34	339 223	Wiper, Felt		1
7	736 767	Ring, PTO Spacer (.323)	1	35	753 232	Piston, Shift		1
	736 797	Ring, PTO Spacer (.328)	} (As Req'd)	36	927 643	Washer, Piston Nut		1
	736 896	Ring, PTO Spacer (.313)		37	688 464	Nut, Flexloc		1
	736 897	Ring, PTO Spacer (.318)		38	883 877 001	Tube, Shift Cylinder (2.75" Long)		1
9	265 238	Bolt, 7/16-14 x 1¼ Grade 5		8	39	235 352	Cap, Shift Cylinder	
10	237 393	Carrier, PTO	1	40	265 769	Bolt, ¼-20 x 3¾ Grade 5		4
11	742 797	Shaft, PTO Output	1	42	675 326	O-ring, 1 5/8 I.D.		1
12	432 427	Gear, Clutch	1	46	432 529	Gear, PTO Declutch		1
13	762 288	Ring, Snap, PTO Output Shaft	1	47	927 744	Washer, PTO Declutch Gear Special		1
P.T.O. AND DIRECT PUMP DRIVE								
14	432 426	Collar, Clutch	1	48	724 622	Capscrew, Nytok Ferryhead 5/8 x 18 x 2		1
15	367 254	Fork, PTO Shift	1	DIRECT PUMP DRIVE ONLY				
16	265 768	Bolt, 7/16-14 x 2¼ Grade 5	2	9	265 238	Bolt, 7/16-14 x 1¼ Grade 5		8
17	947 223	Wire, #18 Gauge (.048) x 5½ Lock	1	43	432 494	Gear, Pump Drive		1
18	427 375	Gasket, PTO Carrier	1	44	724 244	Set Screw, Socket HD, Nylok		2
19	265 845	Bolt, 7/16-20 x 1¼ Grade 5	6	45	792 867	Plate, Mounting		1
20	468 583	Housing, PTO	1					
21	265 343	Bolt, ¼-20 x ½ Grade 5	4					
22	792 866	Plate, PTO Cover	1					
23	427 376	Gasket, PTO Cover Plate	1					
24	758 328	Plug, 1" Welch	1					
25	746 628	Plunger	1					
26	927 427	Washer, Copper	1					
27	798 245	Switch, Shift Indicating	1					
28	675 224	O-ring, 1¾ I.D.	3					

-PM11-

LOCKOUT and related parts

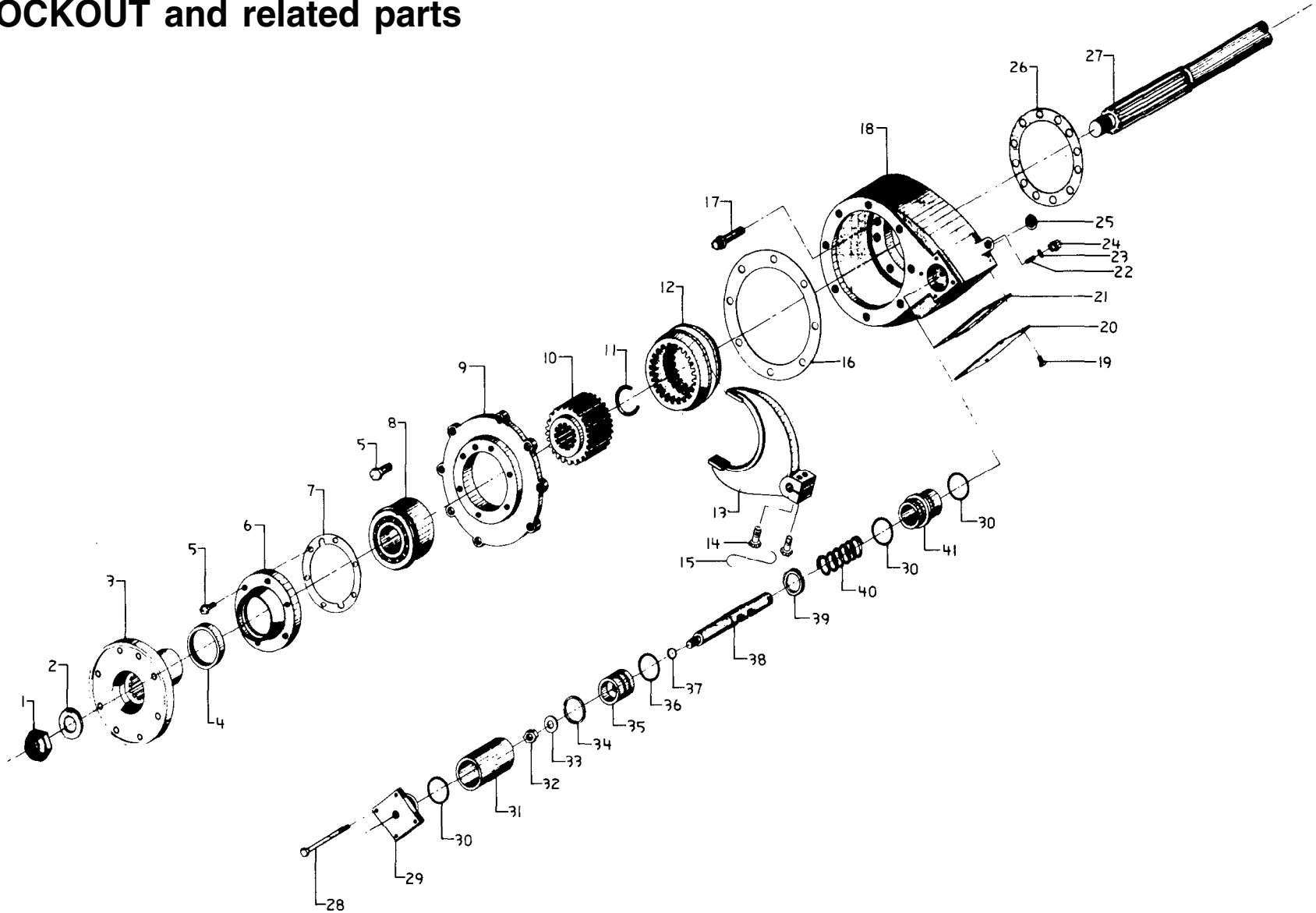

LOCKOUT AND RELATED PARTS

ITEM	PART NO.	DESCRIPTION	QTY				
1	688 633	Nut, Self Locking 1¼-18	1	30 675 224	O-Ring, 1¾ I.D.		3
2	927 775 005	Washer, Lockout Flange Nut	1	31 883 887 001	Tube, Shift Cylinder (2.75" Long)		1
3	*	Flange or Yoke, Front Output	1	32 688 464	Nut, Flexloc		1
4	732 358	Seal, Front Output	1	33 927 643	Washer, Piston Nut		1
5	265 238	Bolt, 7/16-14 × 1¼ Grade 5	14	34 675 326	O-Ring, 1 5/8 I.D.		1
6	237 379	Carrier, Output Seal	1	35 753 232	Piston, Shift		1
7	427 438	Gasket, Output Seal Carrier	1	36 339 223	Wiper, Felt		1
8	232 376	Bearing, Lockout Carrier Ball	1	37 782 288	O-Ring, Piston Seal		1
9	237 378	Carrier, Lockout Bearing	1	38 742 799	Shaft, Lockout Shift		1
10	432 532	Gear, Lockout	1	39 736 747	Ring, Stop		1
11	736 833	Ring, Retaining	1	40 777 477	Spring, Lockout Shift Shaft		1
12	432 426	Collar, Clutch	1	41 883 482	Tube, Lockout Shift Cylinder Adapter		1
13	367 254	Fork, Lockout Shift	1				
14	265 768	Bolt, 7/16-20 × 1½ Grade 5	2	* TO SPECIFICATION. CHECK EXISTING PART BEFORE ORDERING.			
15	947 233	Wire, #18 Gauge (.048) × 5½ Lock	1				
16	427 375	Gasket, Lockout Carrier	1				
17	265 845	Bolt, 7/16-14 × 1¼ Grade 5	6				
18	468 633	Housing, Lockout	1				
19	265 343	Bolt, ¼-20 × ½ Grade 5	4				
20	792 866	Plate, Lockout Cover	1				
21	427 376	Gasket, Lockout Cover Plate	1				
22	746 628	Plunger	1				
23	927 427	Washer, Copper	(As Req'd) 1				
24	798 245	Switch, Shift Indicating	1				
25	758 328	Plug, 1" Welch	1				
26	427 499	Gasket, Lockout Housing	1				
27	432 528	Gear, 26/74 Sun	1				
	769 386	Shaft, 26/74 Inner	4				
	742 973	Shaft, 50/50 Inner					
28	265 769	Bolt, ¼-20 × 3¾ Grade 5	1				
29	235 352	Cap, Shift Cylinder	1				

- P M 13 -

LOWER SHAFT and related parts 26/74 PROPORTIONAL DIFFERENTIAL

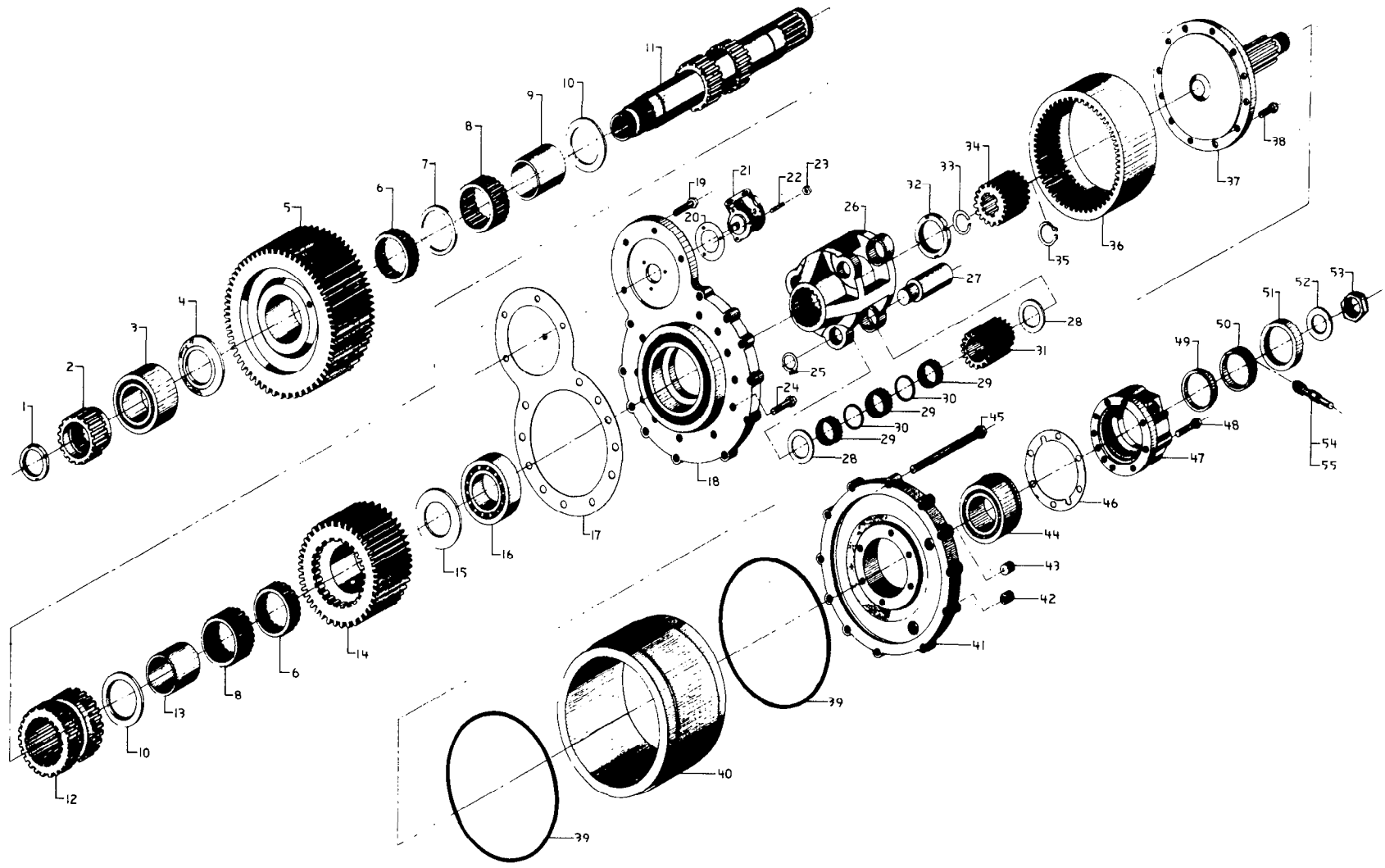

—PM14—

26/74 LOWER SHAFT AND RELATED PARTS

ITEM	PART NO.	DESCRIPTION	QTY					
1	688 645	Nut, Lockout Clutch Gear	1	32	688 644	Nut, Planet Carrier		1
2	432 529	Gear, Lockout Clutch	1	33	736 987	Ring, Retaining		1
3	232 378	Bearing, Front Ball	1	34	432 584	Gear, Sun (22 Tooth)		1
4	736 873	Washer, Front Thrust	1	35	762 327	Snap Ring, Sun Gear		1
5	432 484	Gear, Underdrive (66 Tooth)	1	36	432 526	Gear, Internal (62 Tooth)		1
6	765 284	Bearing, Needle, Narrow	2	37	742 963	Shaft, Planetary Rear Output		1
7	736 835	Ring, Needle Bearing Spacer	1	38	265 965	Bolt, 3/8-16 × 1½ Grade 5		12
8	765 285	Bearing, Needle, Wide	2	39	675 279	O-Ring, 13 I.D.		2
9	233 434	Race, Needle Bearing, Front	1	40	468 627	Housing, Planetary		1
10	927 694	Washer, Inner Thrust	2	41	235 397	Cap, Planetary Carrier		1
11	742 953	Shaft, Planetary, Lower	1	42	758 274	Plug, Drain, Magnetic, ¾ Pipe		1
12	432 485	Collar, Clutch	1	43	758 268	Plug, Fill, ¾ Pipe		1
13	233 433	Race, Needle Bearing, Rear	1	44	232 379	Bearing, Planetary Carrier Cap		1
14	432 488	Gear, Direct Drive (48 Tooth)	1	45	265 923	Bolt, 7/16-14 × 7 Grade 5		12
15	927 696	Washer, Rear Thrust	1	46	427 372	Gasket, Rear Output Seal Carrier		1
16	232 369	Bearing, Rear Ball	1	47	237 382	Carrier, Rear Seal		1
17	427 437	Gasket, Rear Face Plate	1	48	265 369	Bolt, 7/16-14 × 2¾ Grade 5		6
18	793 283	Plate, Planetary Rear Face Cover	1	49	736 872	Ring, Speedometer Gear Spacer		1
19	265 238	Bolt, 7/16-14 × 1¼ Grade 5	4	50	432 432	Gear, Speedometer Drive		1
20	427 435	Gasket, Oil Pump	1	51	732 333	Seal, Rear Output		1
21	786 283	Pump, Oil	1	52	927 775 006	Washer, Rear Output Yoke		1
22	788 546 005	Stud, ¼-20 × ¼-28 × 1¼	3	53	688 642	Nut, 1¾-16 Self Locking		1
23	688 492	Nut, ¼-28	3	54	432 429	Gear, Speedometer Driven (13 Tooth)		1
24	265 363	Bolt, ½-13 × 1½ Grade 5	11	55	883 473	Sleeve, Speedometer Driven Gear		1
25	762 266	Ring, Planet Pin Snap	3					
26	237 387	Carrier, Planet	1					
27	746 684	Pin, Planet	3					
28	736 868	Spacer, Planet Pin	6					
29	233 437	Bearing, Planet Pin Needle	9					
30	736 869	Ring, Planet Pin Needle Brg. Spcr	6					
31	432 525	Gear, Planet (20 Tooth)	3					

LOWER SHAFT and related parts 50/50 PROPORTIONAL DIFFERENTIAL

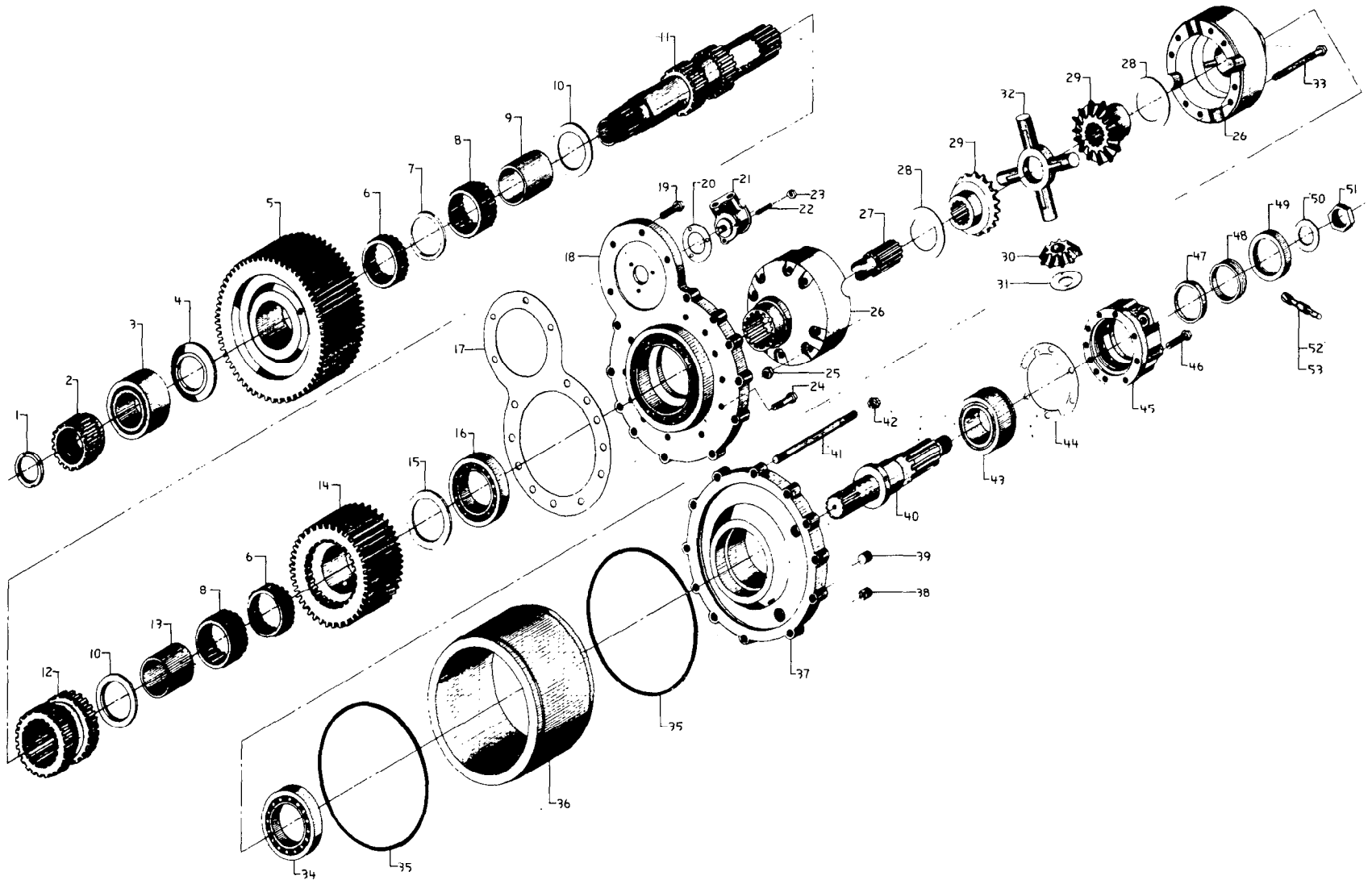

—PM16—

50/50 LOWER SHAFT AND RELATED PARTS

ITEM	PART NO.	DESCRIPTION	QTY				
1	688 645	Nut, Lockout Clutch Gear	1	31 927 738	Washer, Differential Pinion		4
2	432 529	Gear, Lockout Clutch Gear	1	32 277 264	Gross, Differential Spider		1
3	232 378	Bearing, Front Ball	1	33 265 754	Bolt, 5/8-18 x 5 Grade 5		8
4	736 873	Washer, Front Thrust	1	34 232 382	Bearing, Differential Case Ball		1
5	432 484	Gear, Underdrive (66 Tooth)	1	35 675 279	O-Ring, 13" I.D.		2
6	765 284	Bearing, Needle, Narrow	2	36 468 672	Housing, Differential		1
7	736 835	Ring, Needle Bearing Spacer	1	37 235 434	Cap, Differential Carrier		1
8	765 285	Bearing, Needle, Wide	2	38 758 274	Plug, Drain, Magnetic, 3/4 Pipe		1
9	233 434	Race, Needle Bearing, Front	1	39 758 268	Plug, Fill, 3/4 Pipe		1
10	927 694	Washer, Inner Thrust	2	40 742 974	Shaft, Rear Output		1
11	742 972	Shaft, Differential Lower	1	41 788 487	Stud, 7/16-14 x 10 3/4		12
12	432 485	Collar, Clutch	1	42 688 287	Nut, 7/16-14		12
13	233 433	Race, Needle Bearing, Rear	1	43 232 383	Bearing, Rear Output Shaft Ball		1
14	432 488	Gear, Direct Drive (48 Tooth)	1	44 427 372	Gasket, Seal Carrier		1
15	927 725	Washer, Rear Thrust	1	45 237 382	Carrier, Rear Seal		1
16	232 384	Bearing, Ball, Rear	1	46 265 369	Bolt, 7/16-14 x 2 3/4 Grade 5		6
17	427 437	Gasket, Rear Face Plate	1	47 736 872	Ring, Speedometer Gear Spacer		1
18	793 325	Plate, Differential Rear Face Cover	1	48 432 432	Gear, Speedometer Drive		1
19	265 238	Bolt, 7/16-14 x 1 1/4 Grade 5	4	49 732 333	Seal, Rear Output		1
20	427 435	Gasket, Oil Pump	1	50 927 775 006	Washer, Rear Output Yoke		1
21	786 283	Pump, Oil	1	51 688 642	Nut, 1 3/4-16 Self Locking		1
22	788 546 005	Stud, 1/4-20 x 1/4-28 x 1 1/4	3	52 432 429	Gear, Speedometer Driven (13 Tooth)		1
23	688 492	Nut, 1/4-28, Esna	3	53 883 473	Sleeve, Speedometer Driven Gear		1
24	265 363	Bolt, 1/2-13 x 1 1/2 Grade 5	11				
25	688 256	Nut, 5/8-18	8				
26	468 682	Set, Differential Case	1				
27	742 973	Shaft, Inner	1				
28	927 737	Washer, Differential Side Gear Thrust	2				
29	432 535	Gear, Differential Side	2				
30	432 536	Gear, Differential Pinion	4				

OIL PIPING ASSEMBLY

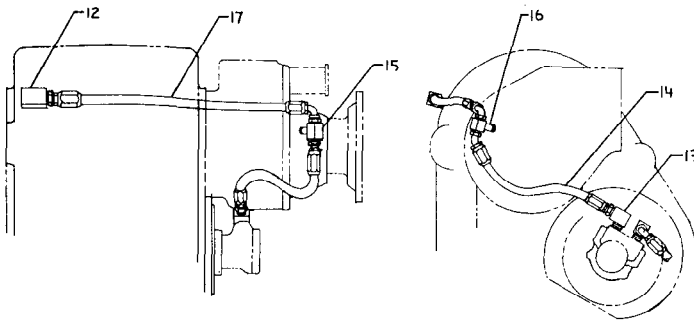

PTO AND DIRECT PUMP DRIVE

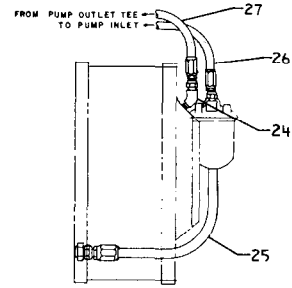

PROPORTIONING DIFFERENTIAL
50/50 (SAME AS 26/74 EXCEPT AS SHOWN)

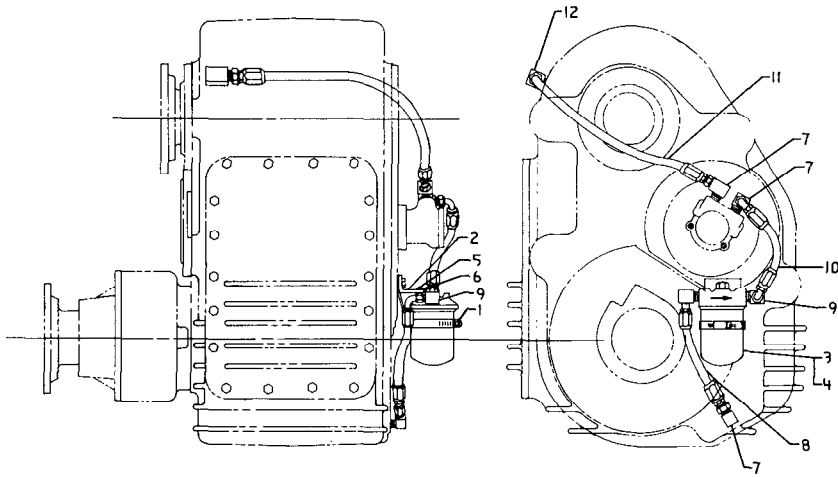

BASIC DECLUTCH CASE

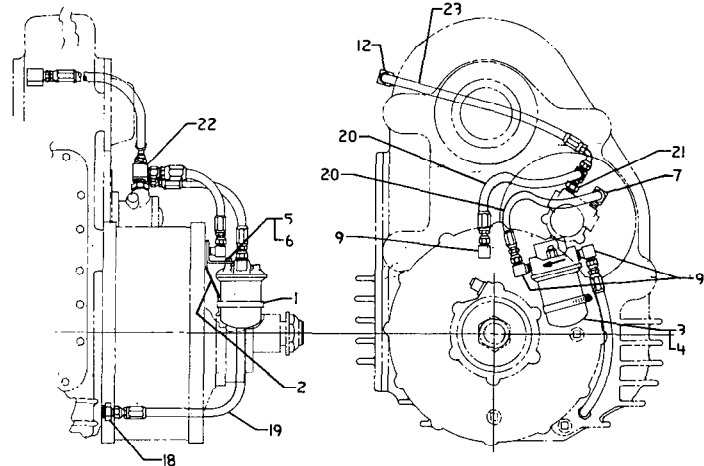

PROPORTIONING DIFFERENTIAL
26/74 SHOWN

LUBRICATION PLUMBING

ITEM	PART NO.	DESCRIPTION	QTY	ITEM	PART NO.	DESCRIPTION	QTY	
							27/24	50/50
BASIC DECLUTCH CASE				27/24 or 50/50 PD CASE				
1	255 244	Hose Clamp	1	18	357 288	Adapter, 1/2P × 9/16-18	1	1
2	273 688	Bracket, Filter Mounting	1	19	469 822 012	Hose Ass'y, Sump-Filter	1	—
3	345 262	Housing, Filter	1	20	469 822 013	Hose Ass'y, Filter-Pump & Pump-Diff. Housing	2	—
4	345 263	Cartridge, Filter	1					
5	724 386	Screw, Self Tapping, 1/4-20 × 1/2	2	21	356 255	Reducer, 1/2P × 3/8P	1	1
6	927 338	Washer, Spring Lock, 1/4	2	22	357 954	Tee, 9/16-18×3/8P×9/16-18	1	1
7	357 697	Elbow, Male 90°, 1/2P × 9/16-18	1	23	469 822 011	Hose Ass'y, Pump-Housing	1	1
8	469 783	Hose Assembly, Filter-Pump	1	24	357 952	Elbow, 45°, 3/8NPT×9/16-18	—	1
9	357 628	Elbow, Male 90°, 3/8P × 9/16-18	2	25	469 822 014	Hose Ass'y, Sump-Filter	—	1
10	469 782	Hose Assembly, Filter-Pump	1	26	469 822 015	Hose Ass'y, Filter-Pump	—	1
11	469 788	Hose Assembly, Pump-Housing	1	27	469 822 016	Hose Ass'y, Pump-Diff. Hsg.	—	1
12	357 935	Elbow 90°, 1/4MP-3/8FP	1					
PTO OR DIRECT PUMP DRIVE								
13	357 929	Elbow, 90°, 1/2MP-3/8FP	1					
14	469 779	Hose Assembly, Pump-Tee	1					
15	357 385	Tee, 9/16-18 (2) × 1/4FP	1					
16	355 584	Nipple, 1/4P × 1-1/2	1					
17	469 778	Hose Assembly, Tee-Housing	1					

Overhaul Kits

PART NO.	DESCRIPTION
233 306	Bearing Kit, TC 140 (Declutch)
233 307	Bearing Kit, TC (with 50/50 Differential)
233 308	Bearing Kit, TC 140 (with 26/74 Differential)
233 311	Bearing Kit, Declutch & PTO
295 309	Shift Cylinder Overhaul Kit
427 303	Seal and Gasket Kit, TC 140 (Declutch)
427 305	Seal and Gasket Kit, TC 140 (with 50/50 or 26/74 Differential)
432 330	Pinion Kit, TC 140 (with 50/50 Differential)
468 682	Set Differential Case (50/50 Differential)